

## MODELLING AND RESEARCH INTO THE VIBRATIONS OF TRUCK CRANE

*Tomasz Geisler, Wojciech Sochacki*

*Institute of Mechanics and Machine Design Foundations  
Czestochowa University of Technology, Poland  
geisler@imipkm.pcz.czyst.pl, sochacki@imipkm.pcz.czyst.pl*

**Abstract.** In this paper, the modelling of and research into the vibrations of a truck crane are considered. The finite element method, using a COSMOS/M package, was applied to build the model and an analytical method was used to build a discrete-continuous model of the crane. The research concerns changes in the frequency of vibrations for flexural vibrations in the telescopic extension arm in the lifting plane. Diagrams containing changes in the frequency of vibrations for chosen values of the geometrical parameters and the load are presented as the solution results to the vibration problem of the tested system. Conclusions are also drawn and their implications discussed.

### Introduction

The problem of modelling the dynamics of a truck crane is a complex problem which requires the following factors to be taken into account in the building of the model: the fundamental and additional units of the crane as well as, the system of the majority of the forces and masses loaded in the systems. The above mentioned problems have been considered in many works.

In 2005, Posiadala wrote a monograph on the modelling of and research into the dynamics of a self-propelled truck crane. The free and parametric vibrations of the system of changes in the crane radius of a DUT 0203 crane was analysed by Sochacki and Tomski [2]. The free vibrations of a laboratory model of a truck crane were analysed by Sochacki in [3]. In [4], Towarek conducted investigations into the influence of a flexible soil foundation on the stability of a crane boom during its rotation. Research into the stability of a truck crane during the realisation of different strategies for the control of operational motions was performed by Klosinski and Janusz in [5]. Sun and Kleeberger in [6] analysed the influence of control and forced systems on the dynamics of a self-propelled crane. In his habilitation thesis, Maczyński [7] presented methods of control of rotation for offshore type cranes to minimise final oscillations of the load. Trombski and Towarek in [8, 9] analysed the influence of foundation rheology on the dynamics of a crane. The vibrations of a truck crane were analysed by Jedlinski in [10].

The construction of the units and research into the dynamics of a chassis frame were presented in earlier works about MES modelling [11, 12]. Later works considered the influence of the remaining units of the truck crane, including the influence of the crane boom, on the free vibrations of the crane [1, 2].

Models resulting from the assumption of two methods of modelling the dynamic systems are presented in this paper. Among them are: a discrete model built applying MES, and a theoretically worked out discrete-continuous model.

The proposed models consist of coupled elements of the crane. The following elements were taken into account in the models:

- chassis frame, which is the basic lifting element of the crane, resting on four extended stays based on a foundation
- rotational frame (body), performing rotational movement towards vertical axis (movement in rotational plane)
- crane boom, rotationally mounted in body, performing movement towards vertical axis (lifting plane) and movement of reciprocal extension of units (telescopic movement)

The frequency of vibrations of the tested systems in relation to the angle of crane boom lifting, length of the crane boom, load mass and the length of its suspension for MES and discrete-continuous (analytical) models are presented as the results of comparative studies. Additionally, the form of vibrations corresponding to the tested basic frequency of transverse vibrations of the crane boom in the plane of its lifting was introduced for the MES model.

## 1. MES model of a crane

The main units of a DST-0285 crane, in the form of a chassis frame, a body frame and the crane boom were designed and made in the “Bumar-Fablok” Factory of Building Machinery and Locomotives in Chrzanow.

Geometrical models were worked out on the basis of available constructional-technical documentation of the chassis frame and of the remaining units and elements. Construction of all the main parts in the form of the main sheets, membranes, webs, ribs, beams and the other essential elements of the construction was considered in the modelling of specified units.

The aim of the performed modelling was to obtain crane models making research possible with respect to determination of the frequency and vibrations of a crane boom for its different configurations.

The elasticity of the support of the crane jib (servo-motor of change in crane radius) and elasticity of the support of the frame (servo-motors of stays) were considered in the model. The elasticity of the liquid in the servo-motor of the support for the crane jib was also taken into account. This elasticity depends on the value of the lifting angle of the crane boom.

The model was built with the use of the finite element method and the COSMOS/M package [13, 14]. A series of necessary simplifications in the construction was applied in the model. Some constructional elements, assembling holes and elements of equipment fastening, sheet shoulders, small radii of cutting out and sheet bends were omitted.

In the modelling, the following basic structural elements were applied to the linear analysis:

- *shell3* - triangular coated thin-walled element of isotropic properties used to model sheets accounting for the main constructional elements of frames and a crane jib
- *solid* - three-dimensional element of isotropic properties used to model slides present between elements of fixed and movable supports, on which the frame rests during working cycle of crane, and slides in crane boom
- *spring* - elastic element used to model elasticity of support elements of frame
- *rbar* - rigid rod element with two nodes used to model elements connecting chassis frame to body frame, and crane boom to body frame
- *mass* - mass element used to model chosen concentrated masses of crane elements (e.g. counterbalances, engine) and load

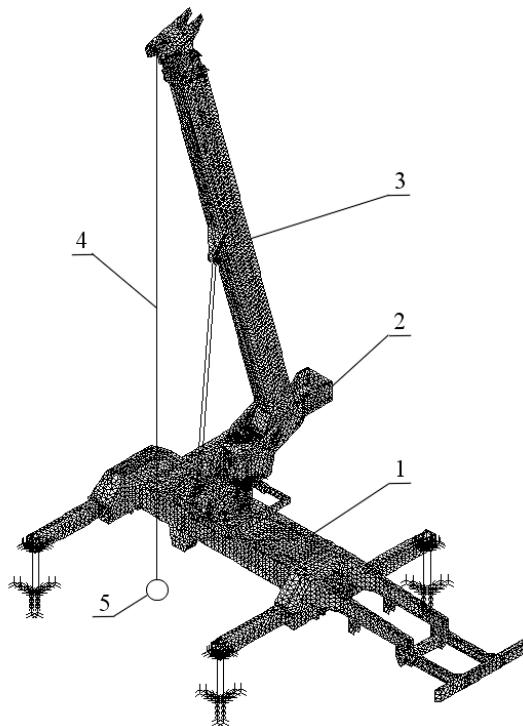

Fig. 1. Model of truck crane (1 - chassis frame, 2 - body frame, 3 - crane boom, 4 - linear system, 5 - mass of load)

All the geometric measurements and properties of the applied elements of the built models were introduced into the program file in a parametrical way determining at first the parameter and later its value. Therefore with a change in the geometrical dimensions of the frame and crane jib elements, consecutive research is possible on the basis of the same model by altering only its parameters.

The load in the form of a mass element, placed on an elastic linear element, which is fixed to the last feeding member, is considered in the model. The majority of masses of crane elements, including the masses of the engine, cabins, hoisting winches, suspensions, servo-motors and the like, is also taken into account.

The model of the system consisting of the connected chassis frame, body frame and the crane boom of a truck crane, is presented in Figure 1.

## 2. Discrete-continuous model of a crane

Modelling should fulfil two basic aims. At first, it should represent the object and its behaviour in the simplest form. On the other hand, the results obtained on the basis of the model should represent object features in the way closest to reality.

Considering the above mentioned aims of modelling, an analytical model (discrete-continuous) of the crane was worked out. The necessity of this type of modelling results from the basic premise, which is the computation speed (analysis) of the object behaviour for its changeable parameters.

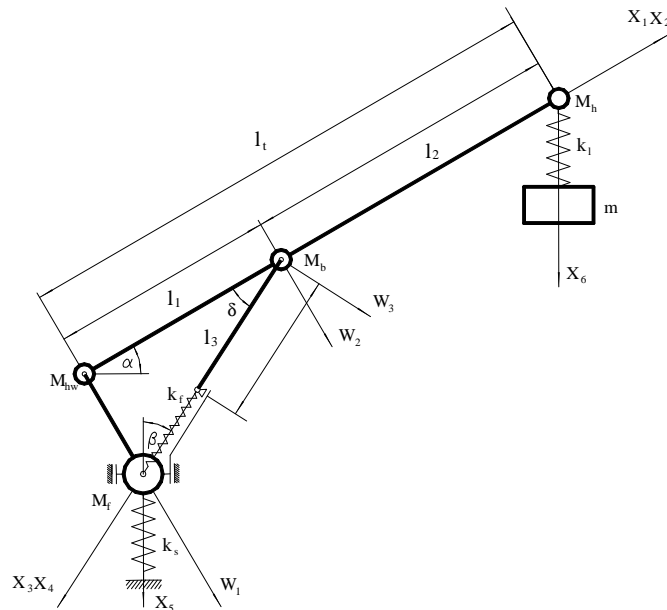

Fig. 2. Discrete-continuous model of crane

Moreover, this method of modelling does not need developed computing systems using MES and makes it easier to introduce changes and adaptations to systems of similar structure. The constructed discrete-continuous model of the crane (Fig. 2) fully corresponds to the real system.

Therefore the mass of the load hung on the line, the real geometry of the system, equivalent masses taking into account: the masses of the boom elements, mass of the hoisting winch and counterweight, were considered. The mass of the boom head and equivalent mass of the whole crane brought to the rotation axis for the crane were also considered. Moreover, the equivalent rigidity of the boom (considering the specific case of parted elements of the boom brought to the rigidity of beams modelling the tested system), elasticity of the servo-motor of change in the crane radius, elasticity of the linear system and elasticity of the stays were taken into account.

During building the model, the following simplifications were assumed:

- beams of the system are Bernoulli-Euler's beams
- chassis frame of the crane is inelastic
- spring modelling replacing elasticity of supports is applied at fixing place of the boom in the rotating frame
- mass modelling chassis part of crane with rotating frame is replaced only vertically in the lifting plane of the boom

The problem of system vibrations is formulated using Hamilton's principle

$$\delta \int_{t_1}^{t_2} (T - V) dt = 0 \quad (1)$$

Kinetic energy  $T$  is the sum of the kinetic energies of the crane elements modelled by the beams and concentrated masses in the system:

$$\begin{aligned} T = & \sum_{i=1}^3 \frac{1}{2} \int_0^{l_i} \rho_i A_i \left[ \frac{\partial W_i(x_i, t)}{\partial t} \right]^2 dx_i + \frac{1}{2} M_{hw} \left[ \frac{\partial W_1(0, t)}{\partial t} \right]^2 + \\ & + \frac{1}{2} M_b \left[ \frac{\partial W_2(0, t)}{\partial t} \right]^2 + \frac{1}{2} M_f \left[ \frac{dX_5(t)}{dt} \right]^2 + \frac{1}{2} M_h \left[ \frac{\partial W_2(l_2, t)}{\partial t} \right]^2 + \frac{1}{2} m \left[ \frac{dX_6(t)}{dt} \right]^2 \end{aligned} \quad (2)$$

where:

$\rho_i$  - density of beam material

$A_i$  - cross-sectional area of a beam,  $i = 1, 2, 3$

$M_{hw}$  - equivalent mass modelling masses of hoisting winch and counterweight

$M_b$  - equivalent mass modelling mass of piston rod of servo-motor of change in crane radius

$M_f$  - equivalent mass modelling mass of crane chassis

$M_h$  - mass of roller slope

$m$  - mass of the load

$t$  - time

Total potential energy  $V$  of the system is the sum of the energies of the internal forces and work of the external forces and is equal to:

$$V = \sum_{i=1}^3 \frac{1}{2} \int_0^{l_i} E_i J_i \left[ \frac{\partial^2 W_i(x_i, t)}{\partial x_i^2} \right]^2 dx_i - \sum_{i=1}^3 \frac{1}{2} \int_0^{l_i} P_i \left[ \frac{\partial W_i(x_i, t)}{\partial x_i} \right]^2 dx_i + \frac{1}{2} \left[ (k_f + k_s) (X_5(t) \cos \beta)^2 - 2k_s X_4(t) X_5(t) \cos \beta + k_f X_4(t)^2 + k_l (X_6(t) - W_2(l_2, 0) \cos \alpha)^2 \right] \quad (3)$$

where:  $P_2 = mg \sin \alpha$ ,  $P_1 = mg \sin \alpha - P_3 \cos \delta$ ,  $P_3 = k_f x_4$ ,  $\beta = 90^\circ - (\alpha + \delta)$ ,

$E_i$  - Young's modulus of beam material

$J_i$  - moment of inertia of beam intersection,  $i = 1, 2, 3$

$k_s$  - replacing coefficient of elasticity modelling elasticity of stays

$k_f$  - coefficient of elasticity modelling elasticity of liquid in servo-motor of change in outreach

The substitution of (2) and (3) into (1), after adequate transformations, leads to equations of motion. The geometric boundary conditions when introduced into equation (1) with the consideration of equations (2) and (3) give supplementary natural boundary conditions. After the separation of variables into the equations of motion and into boundary conditions by substitution:

$$W_i(x_i, t) = w_i(x_i) \cos(\omega t), \quad (i = 1, 2, 3) \quad (4)$$

and 
$$X_i(t) = x_i \cos(\omega t), \quad (i = 4, 5, 6) \quad (5)$$

the following equations of motion have been obtained:

$$E_i J_i w_i^{IV}(x_i) + P_i w_i''(x_i) - \rho_i A_i \omega^2 w_i(x_i) = 0, \quad (i = 1, 2, 3) \quad (6)$$

The geometrical boundary conditions and continuous conditions are as follows:

$$\begin{aligned} w_1(0) \cos \alpha &= x_5 \\ w_1(l_1) &= w_2(0) \\ w_1(0) \cos \alpha &= x_5 + x_4 \cos \alpha \sin \delta \\ w_2(l_2) &= w_2(0) \frac{l_2}{l_1} \\ w_3(0) &= w_2(0) \cos \delta \\ w_3(l_3) \cos \alpha &= x_5 \cos \delta \\ w_1^I(l_1) &= w_2^I(0) \end{aligned} \quad (7)$$

The natural boundary conditions were obtained in the form of:

$$\begin{aligned}
w_1''(0) &= 0, w_2''(l_2) = 0, w_3''(0) = 0, w_3''(l_3) = 0, E_1 J_1 w_1''(l_1) = E_2 J_2 w_2''(0) \\
&[E_1 J_1 w_1'''(0) + P_1 w_1'(0) + \omega^2 M_{hw} w_1(0)] \cos \alpha + M_f \omega^2 x_5 - k_s x_5 = 0 \\
E_1 J_1 w_1'''(l_1) + P_1 w_1'(l_1) - E_2 J_2 w_2'''(0) - P_2 w_2'(0) + M_b \omega^2 w_2(0) - k_f x_4 \sin \delta &= 0 \quad (8) \\
E_2 J_2 w_2'''(l_2) + P_2 w_2'(l_2) + M_h \omega^2 w_2(l_2) - m_f \omega^2 x_6 \cos \delta &= 0 \\
M_f \omega^2 x_5 - x_5 (k_f \cos \beta + k_s) - 2k_f x_5 \cos \beta &= 0 \\
m \omega^2 x_6 - k_l [2w_2(l_2) \cos \alpha - x_6] &= 0
\end{aligned}$$

The solution to equation (6) is the function:

$$w_i(x_i) = C_{i1} ch \frac{\lambda_i}{l_i} x_i + C_{i2} sh \frac{\lambda_i}{l_i} x_i + C_{i3} \cos \frac{\bar{\lambda}_i}{l_i} x_i + C_{i4} \sin \frac{\bar{\lambda}_i}{l_i} x_i, \quad (9)$$

where:  $C_{i1} \div C_{i4}$  – constants,

$$\frac{\lambda_i}{l_i} = \sqrt{-\frac{\beta_i^2}{2} + \sqrt{\frac{\beta_i^4}{4} + \gamma_i}}, \quad \frac{\bar{\lambda}_i}{l_i} = \sqrt{\frac{\beta_i^2}{2} + \sqrt{\frac{\beta_i^4}{4} + \gamma_i}},$$

where:  $\gamma_i = \omega^2 \frac{\rho_i A_i}{E_i J_i}$ ,  $\beta_i^2 = \frac{P_i}{E_i J_i}$ ,  $l_i$  – the length of the  $i$ -th beam,  $i = 1, 2, 3$ .

The solution to the boundary problem leads a uniform system of equation towards unknown constants  $C_{ik}$  ( $i = 1, 2, 3, k = 1, 2 \dots 4$ ) and  $x_n$  ( $n = 4, 5, 6$ ). This system in a matrix form can be written as:

$$[a_{pq}] \text{col}\{C_{ik}, x_n\} = 0 \quad (10)$$

If the eigenvalues of matrix  $[a_{pq}]$  are found, the frequency of vibrations of the considered system can be determined.

### 3. Results of computations

The changes in frequency of the vibrations for the chosen values of geometrical parameters and load are presented as the results of the solution to the problem of vibrations of the considered system.

The research concerns changes in the frequency of vibrations of the first, flexural form of vibrations of the crane boom in the lifting plane (Fig. 3).

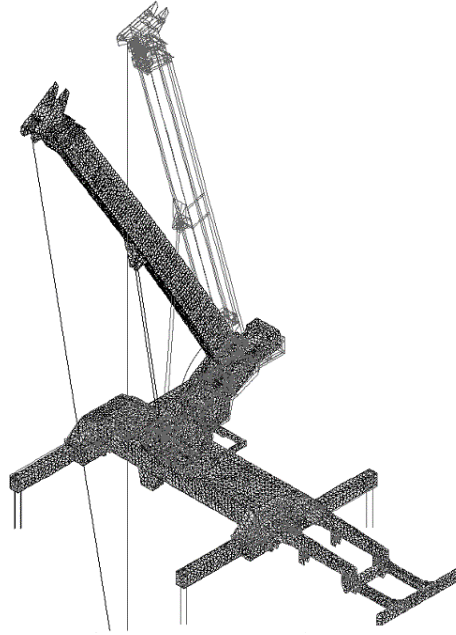

Fig. 3. Flexural form of boom in lifting plane, MES model

The obtained results are presented in diagrams containing courses of changes in the values of vibrational frequency in relation to the chosen parameters. Three-dimensional diagrams, which are the combinations of chosen parameters accepting the constant values of one of them were plotted.

The chosen position of the boom crane with the body frame in relation to the chassis frame was accepted for computations.

The parameters determining the configuration of the boom location in space and dimensions could undergo changes in a specified range. The angle of boom lifting, total length of the boom, weight and length of the hanging load were the changeable parameters.

Research was carried out for the following data:

- lifting angle of the boom:  $\alpha = 0 \div 75^\circ$
- length of boom considering outreach of internal members:  $l_t = 10 \div 24$  m
- value of load weight:  $m = 0 \div 30000$  kg

In Figures 4 and 5, the results of research into the vibrational frequency of the system for a changeable length of the boom ( $l_t = 10 \div 24$  m), and changeable load of the crane ( $m = 5000 \div 30000$  kg) are shown. The lifting angle of the boom was equal to  $\alpha = 75^\circ$ .

The assumed range of changes in chosen parameters  $l_t$  and  $m$  causes part of the received results to be placed in the region of loads exceeding the hoisting capacity



limits for the assumed length of the boom. To demonstrate this fact, in Figures 4 and 5, the curve delimiting the region of safe loads of the crane (area above the curve) from the region of overloading the system (below the curve) is plotted.

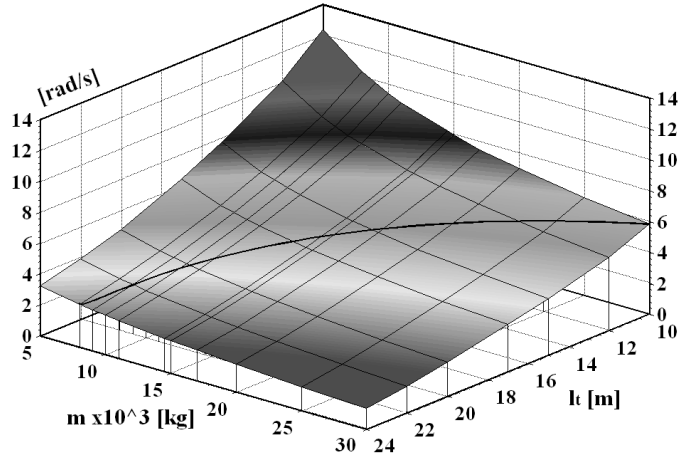

Fig. 4. Diagram of changes in vibrational frequency with changeable value of load, analytical method

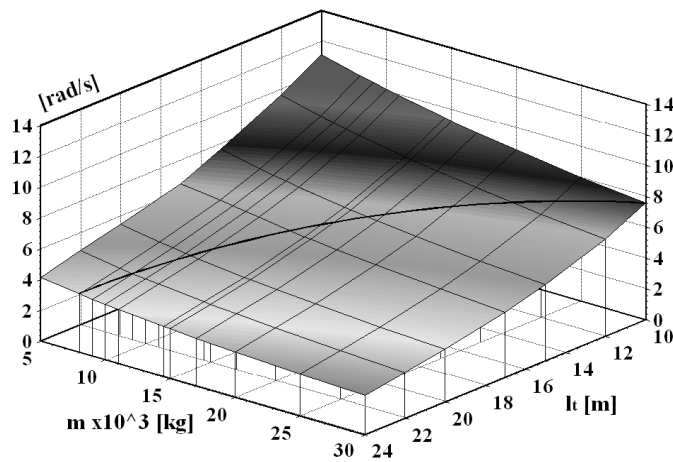

Fig. 5. Diagram of changes in vibrational frequency with changeable value of load, MES method

The following diagrams (Figs 6 and 7) concern changes in the vibrational frequency of the boom crane regarding its changeable length ( $l_i = 10 \div 24$  m) and changeable angle of its inclination ( $\alpha = 0 \div 75^\circ$ ) with a constant load value equaling  $m = 5000$  kg. The length of the line was equal to  $l_l = 5$  m in every tested case.

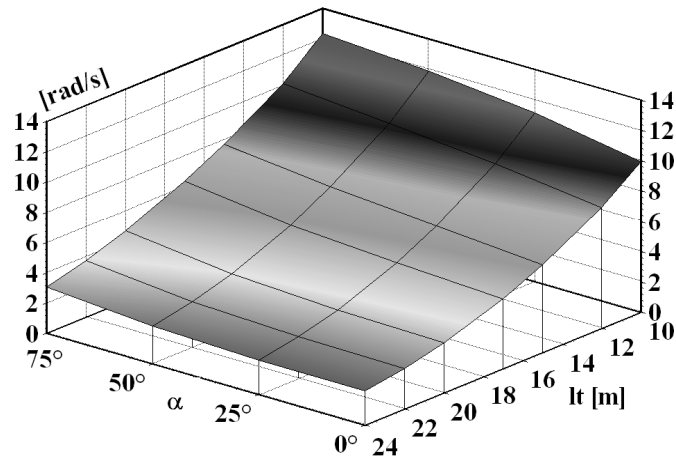

Fig. 6. Diagram of changes in vibrational frequency with changeable angle of boom lifting, analytical method

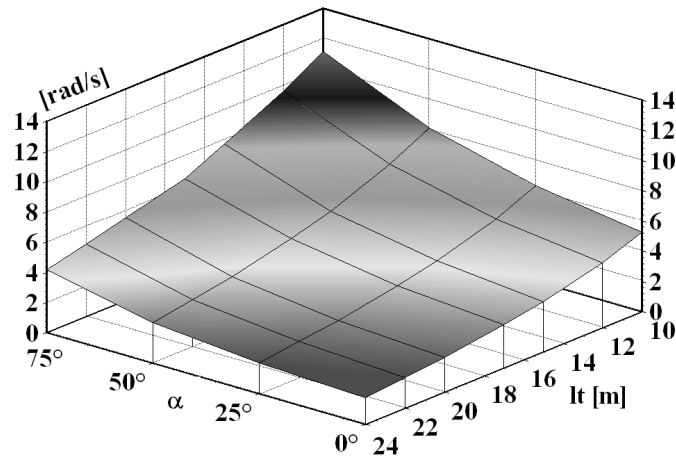

Fig. 7. Diagram of changes in vibrational frequency with changeable angle of boom lifting, MES method

## Conclusions

Vibrations of the boom crane occurred in different planes. They are flexural forms in the lifting plane, flexural in the plane perpendicular to it and forms of torsional vibrations.

Identification of the form on the basis of the analysis of boom displacements was made to determine the value of the vibrational frequency of the sought flexural form of the boom.

Comparative analysis of the research results on the basis of the two models presented in the paper allows the following conclusions to be drawn:

- good agreement between changes in the vibrational frequency of the system with a changeable value of load and length of the boom (Figs. 4 and 5) was obtained, agreement in the results concerns both the values of the obtained vibrational frequency as well as the character of their changes
- in the case of research into the influence of the boom length and the angle of its inclination (Figs 6 and 7), agreement in the character of changes in vibrational frequency and their values above a boom length equal to  $l_t = 15$  m was obtained. Similar vibrational frequencies with slightly different characters of their changes were obtained for smaller lengths of the boom
- agreement in the obtained results indicates the correctness of the built models. Verification of the built models will be possible after carrying out experimental research on the real object (on a crane).

### Acknowledgements

*This research was supported by the Ministry of Science and Higher Education in 2011, Warsaw, Poland (BS).*

### References

- [1] Posiadała B., Modelowanie i identyfikacja modeli i badania dynamiki żurawi samojezdnych, WNT, Warszawa 2005 (in Polish).
- [2] Sochacki W., Tomski L., Free and parametric vibration of the system: telescopic boom-hydraulic cylinder changing the crane radius, The Archive of Mechanical Engineering 1999, XLVI, 3, 257-271.
- [3] Sochacki W., Drgania modelu laboratoryjnego żurawia, Systems 2003, 8, 471-479 (in Polish).
- [4] Towarek Z., The dynamic stability of a crane standing on soil during rotation of the boom, International Journal of Mechanical Sciences 1998, 40(6), 557-574.
- [5] Kłosiński J., Janusz J., Model matematyczny żurawia samojezdnego przeznaczony do badania jego stateczności dynamicznej, Prace Naukowe Instytutu Konstrukcji i Eksploatacji Maszyn Politechniki Wrocławskiej, Nr 85, Konferencje 2002, 25, 239-244 (in Polish).
- [6] Sun G., Kleeberger M., Dynamic response of hydraulic mobile crane with consideration of the drive system, Mechanism and Machine Theory 2003, 38, 1489-1508.
- [7] Maczyński A., Pozycjonowanie i stabilizacja położenia ładunku żurawi wyciągarkowych, AT-H w Bielsku Białej, Rozprawy naukowe 2005, 14 (in Polish).
- [8] Geisler T., Posiadała B., Analiza drgań swobodnych ramy podwozia żurawia samojezdnego, SYSTEMS - Journal of Transdisciplinary Systems Science, VI Międzynarodowa Konferencja Naukowa „Computer Aided Engineering”, Vol. 7(1), Polanica Zdrój 2002, 199-205 (in Polish).
- [9] Towarek Z., Trombski M., Analiza dynamiczna modelu żurawia posadowionego na podatnym podłożu, ZN PŁ Filii w Bielsku-Białej 1993, 14, 21-33 (in Polish).
- [10] Trombski M., Towarek Z., Analiza wpływu reologii podłoża na dynamikę maszyny roboczej w czasie podnoszenia ładunku, Materiały VI Konferencji Naukowej „Problemy rozwoju maszyn roboczych”, Zakopane 1993, 237-244 (in Polish).

- [11] Jedliński W., Analiza drgań żurawia samochodowego, *Rozprawy Inżynierskie* 1986, 34, 81-96. (in Polish)
- [12] Geisler T., Badania wpływu obciążenia na drgania ramy podwozia żurawia samochodowego, XI Międzynarodowe Sympozjum Dynamiki Konstrukcji, Rzeszów Arłamów, *Zeszyty Naukowe Politechniki Rzeszowskiej* 2002, nr 197, *Mechanika*, z. 60, 197-204 (in Polish).
- [13] Geisler T., Analiza drgań swobodnych układu nośnego żurawia samochodowego DST-0285 z uwzględnieniem zmiany konfiguracji układu, *Acta Mechanica et Automatica* 2010, 4, 1 (in Polish).
- [14] COSMOS/M User Guide, Version 1.75, Structural Research and Analysis Corporation, Los Angeles 1995.
- [15] Rusiński E., *Metoda elementów skończonych. System COSMOS/M*, Wydawnictwa Komunikacji i Łączności, Warszawa 1994 (in Polish).