

Please cite this article as:

Michał Guminiak, Initial stability analysis of plates considering continuous internal supports by the BEM, Scientific Research of the Institute of Mathematics and Computer Science, 2009, Volume 8, Issue 1, pages 47-62.

The website: <http://www.amcm.pcz.pl/>

---

Scientific Research of the Institute of Mathematics and Computer Science

---

## INITIAL STABILITY ANALYSIS OF PLATES CONSIDERING CONTINUOUS INTERNAL SUPPORTS BY THE BEM

*Michał Guminiak*

*Institute of Structural Engineering, Poznan University of Technology, Poland  
michal.guminiak@put.poznan.pl*

**Abstract.** An initial stability of Kirchhoff plates is presented in the paper. Using proposed approach, there is no need to introduce Kirchhoff forces at the plate corner and equivalent shear forces at a plate boundary. Two unknown and independent variables are considered at the boundary element node. The Betti theorem is used to derive the boundary integral equation. The collocation version of boundary element method with "constant" type of elements is presented. The source points are located slightly outside a plate boundary, hence the quasi-diagonal integrals of fundamental functions are non-singular. To describe a plate curvature, the set of internal collocation points is introduced.

### Introduction

Initial stability of thin plates considering internal continuous supports is solved using the Boundary Element Method (BEM). Modelling of a plate bending problem with internal plate supports requires modification of governing boundary integral equation. The most popular approach was proposed by Bèzine [1] in which, the forces at the internal supports are treated as unknown variables. This technique is also used by de Paiva and Venturini [2, 3], Hartmann and Zotemantel [4], Abdel-Akher and Hartley [5] and Litewka [6]. The second approach was proposed by Rashed [7] in application of a coupled BEM-flexibility force method in bending analysis of plates with internal supports. Shi [8] applied Bèzine technique to solve free vibration and buckling problem of orthotropic thin plates. This paper presents a modified formulation for bending analysis of plates supported on a boundary with additional internal linear supports. This formulation can be applied in static, dynamic and buckling problems [9-11]. The physical boundary conditions are applied which leads to reduce of number of independent variables by one. In this formulation there is no need to introduce the equivalent shear forces at the boundary and concentrated forces at the plate corners. Similar to Hartley [12], the source points of boundary elements were located slightly outside a plate boundary, hence all of quasi-diagonal integrals are non-singular. Internal support was introduced using Bèzine techniques.

### 1. Integral formulation of thin plate bending in modified approach

On the plate boundary there are considered amplitudes of variables: the shear force  $T_n$ , bending moment  $M_n$ , torsional moment  $M_{ns}$  and deflection  $w$ , angle of rotation in normal direction  $\varphi_n$  and angle of rotation in tangent direction  $\varphi_s$ . Only two of them are independent. The boundary integral equation are derived using Bettie theorem. Two plates are considered: infinite plate, subjected unit concentrated loading and the real one (Fig. 1).

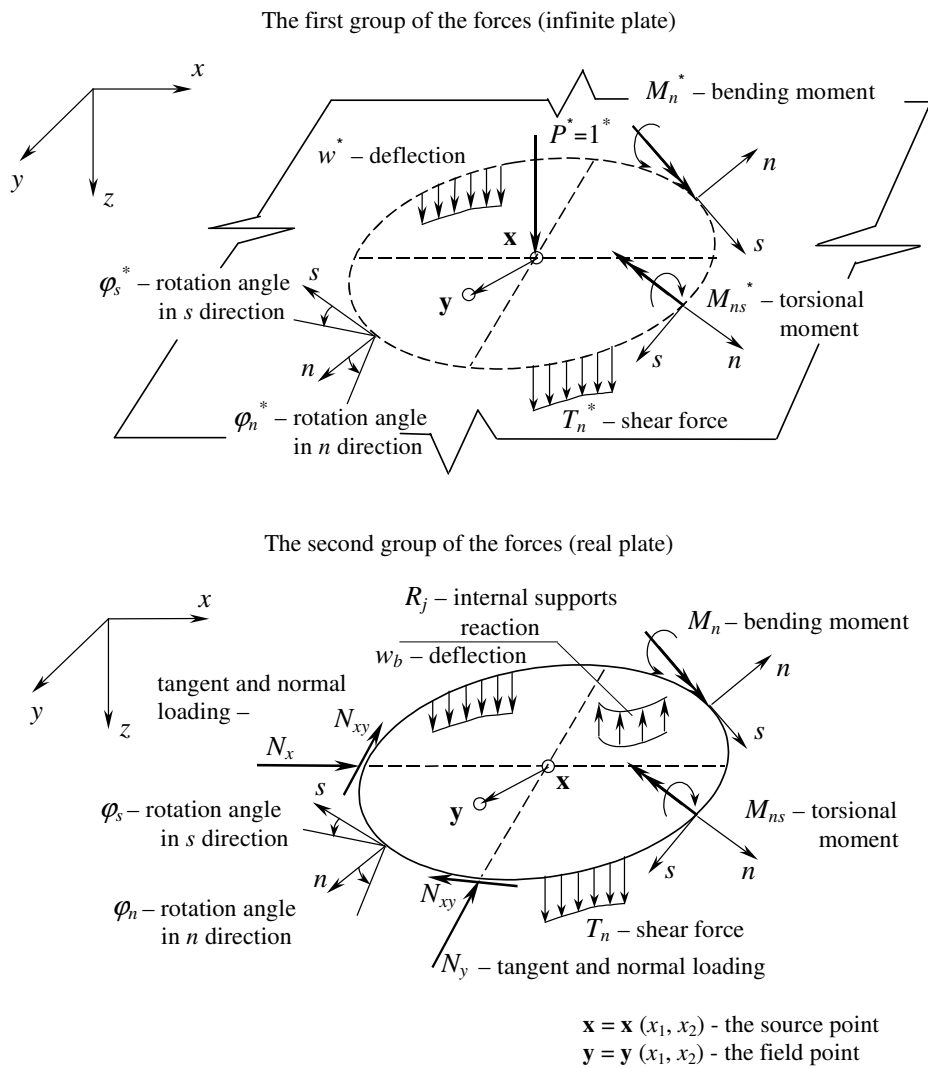

Fig. 1. Variables present in the boundary integral equation

As a result the boundary integral equation are in the form (Fig. 1)

$$\begin{aligned}
c(\mathbf{x}) \cdot w(\mathbf{x}) + \int_{\Gamma} [T_n^*(\mathbf{y}, \mathbf{x}) \cdot w(\mathbf{y}) - M_n^*(\mathbf{y}, \mathbf{x}) \cdot \varphi_n(\mathbf{y}) - M_{ns}^*(\mathbf{y}, \mathbf{x}) \cdot \varphi_s(\mathbf{y})] d\Gamma(\mathbf{y}) = \\
= \int_{\Gamma} [T_n(\mathbf{y}) \cdot w^*(\mathbf{y}, \mathbf{x}) - M_n(\mathbf{y}) \cdot \varphi_n^*(\mathbf{y}, \mathbf{x}) - M_{ns}(\mathbf{y}) \cdot \varphi_s^*(\mathbf{y}, \mathbf{x})] \cdot d\Gamma(\mathbf{y}) + \\
- \int_{\tilde{\Gamma}} R(\mathbf{y}) \cdot w^*(\mathbf{y}, \mathbf{x}) \cdot d\tilde{\Gamma}(\mathbf{y}) + \int_{\Omega} \left( N_x \frac{\partial^2 w}{\partial x^2} + 2N_{xy} \frac{\partial^2 w}{\partial x \partial y} + N_y \frac{\partial^2 w}{\partial y^2} \right) w^*(\mathbf{y}, \mathbf{x}) \cdot d\Omega(\mathbf{y})
\end{aligned} \quad (1)$$

where  $R(\mathbf{y})$  is the reaction force along internal linear supports.

The fundamental solution of biharmonic equation

$$\nabla^4 w = \frac{1}{D} \cdot \bar{\delta}(\mathbf{y} - \mathbf{x}) \quad (2)$$

is given as a Green function

$$w^*(\mathbf{y}, \mathbf{x}) = \frac{1}{D} \frac{r^2}{8\pi} \ln r \quad (3)$$

for a thin xisotropic plate,  $r = |\mathbf{y} - \mathbf{x}|$ ,  $\bar{\delta}$  is Dirac delta and

$$D = \frac{E h_p^3}{12 (1 - \nu_p^2)} \quad (4)$$

is a plate stiffness. The coefficient  $c(\mathbf{x})$  is assumed as:

$$\begin{aligned}
c(\mathbf{x}) = 1, \quad \text{when } \mathbf{x} \text{ is located inside the plate region,} \\
c(\mathbf{x}) = 0.5, \quad \text{when } \mathbf{x} \text{ is located on the smooth boundary,} \\
c(\mathbf{x}) = 0, \quad \text{when } \mathbf{x} \text{ is located outside the plate region.}
\end{aligned}$$

The second equation can be derived by substituting of unit concentrated force  $P^* = 1^*$  unit concentrated moment  $M_n^* = 1^*$ . It is equivalent to differentiate the first boundary integral equation (1) on  $n$  direction in point  $\mathbf{x}$  on a plate boundary.

$$\begin{aligned}
c(\mathbf{x}) \cdot \varphi(\mathbf{x}) + \int_{\Gamma} [\overline{T}_n^*(\mathbf{y}, \mathbf{x}) \cdot w(\mathbf{y}) - \overline{M}_n^*(\mathbf{y}, \mathbf{x}) \cdot \varphi_n(\mathbf{y}) - \overline{M}_{ns}^*(\mathbf{y}, \mathbf{x}) \cdot \varphi_s(\mathbf{y})] d\Gamma(\mathbf{y}) = \\
= \int_{\Gamma} [T_n(\mathbf{y}) \cdot \overline{w}^*(\mathbf{y}, \mathbf{x}) - M_n(\mathbf{y}) \cdot \overline{\varphi}_n^*(\mathbf{y}, \mathbf{x}) - M_{ns}(\mathbf{y}) \cdot \overline{\varphi}_s^*(\mathbf{y}, \mathbf{x})] \cdot d\Gamma(\mathbf{y}) + \\
- \int_{\tilde{\Gamma}} R(\mathbf{y}) \cdot \overline{w}^*(\mathbf{y}, \mathbf{x}) \cdot d\tilde{\Gamma}(\mathbf{y}) + \int_{\Omega} \left( N_x \frac{\partial^2 w}{\partial x^2} + 2N_{xy} \frac{\partial^2 w}{\partial x \partial y} + N_y \frac{\partial^2 w}{\partial y^2} \right) \overline{w}^*(\mathbf{y}, \mathbf{x}) \cdot d\Omega(\mathbf{y})
\end{aligned} \quad (5)$$

where

$$\begin{aligned} & \left\{ \overline{T_n^*}(\mathbf{y}, \mathbf{x}), \overline{M_n^*}(\mathbf{y}, \mathbf{x}), \overline{M_{ns}^*}(\mathbf{y}, \mathbf{x}), \overline{w^*}(\mathbf{y}, \mathbf{x}), \overline{\varphi_n^*}(\mathbf{y}, \mathbf{x}), \overline{\varphi_s^*}(\mathbf{y}, \mathbf{x}) \right\} = \\ & = \frac{\partial}{\partial n(\mathbf{x})} \left\{ T_n^*(\mathbf{y}, \mathbf{x}), M_n^*(\mathbf{y}, \mathbf{x}), M_{ns}^*(\mathbf{y}, \mathbf{x}), w^*(\mathbf{y}, \mathbf{x}), \varphi_n^*(\mathbf{y}, \mathbf{x}), \varphi_s^*(\mathbf{y}, \mathbf{x}) \right\} \end{aligned} \quad (6)$$

Internal collocation points are introduced to describe the plate curvature [8, 11]. Idea of a new approach and formulation of boundary integral equation in plate bending is shown on Figure 2.

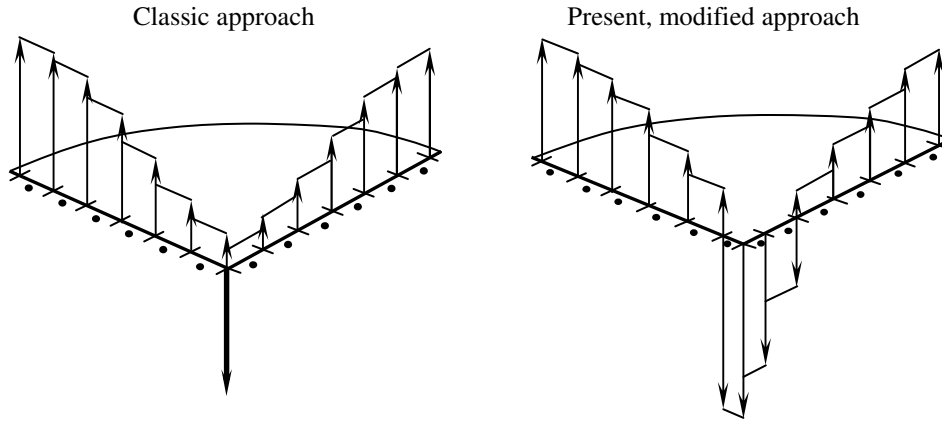

Fig. 2. Distribution of the support reaction - classic and present approach

## 2. Boundary conditions

The boundary conditions for clamped edge are formulated as follows:

$$\begin{cases} w = 0 \\ \varphi_n = 0 \\ \varphi_s = 0 \\ M_{ns} = 0 \end{cases} \quad (7)$$

The unknown variables are: the bending moment  $M_n$  and the shear force  $T_n$  (Fig. 3).

For simply-supported edge the boundary conditions have the form:

$$\begin{cases} w = 0 \\ \varphi_s = 0 \\ M_n = 0 \\ M_{ns} = 0 \end{cases} \quad (8)$$

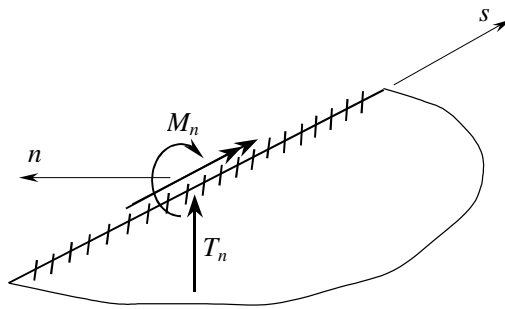

Fig. 3. Variables presented on the clamped edge

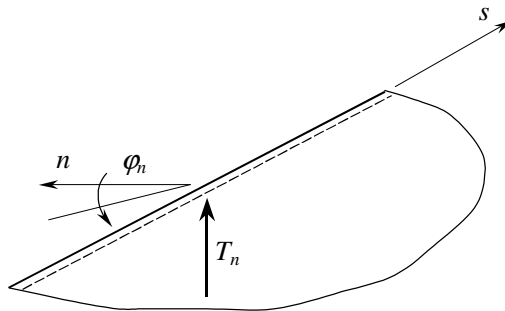

Fig. 4. Variables presented on the simply-supported edge

The unknown values are: the shear force  $T_n$  and the angle of rotation in direction  $n$ ,  $\varphi_n$  (Fig. 4).

Free edge can be described by the following boundary conditions:

$$\begin{cases} T_n = 0 \\ M_n = 0 \\ M_{ns} = 0 \end{cases} \quad (9)$$

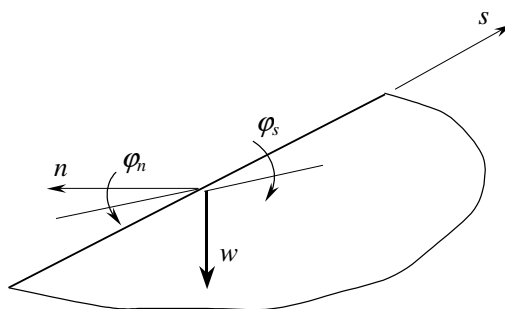

Fig. 5. Variables presented on the free edge

The unknown variables are: the deflection  $w$  and the angles of rotation  $\varphi_n$ ,  $\varphi_s$  (Fig. 5). Because the relation between  $\varphi_s$  and  $w$  is known,  $\varphi_s = \frac{\partial w}{\partial s}$ , there are only two independent values:  $w$  and  $\varphi_n$ . After discretization of a plate boundary into constant elements having the same length, parameter  $\frac{\partial w}{\partial s}(\mathbf{y})$  can be calculated approximately by constructing a differential expression using deflections of three neighbouring nodes (Fig. 6).

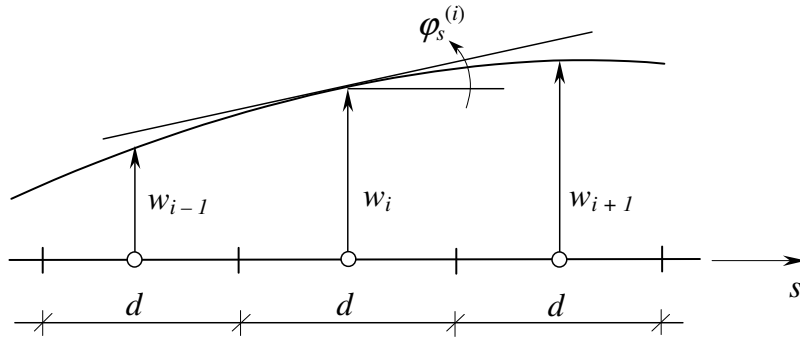

Fig. 6. Calculation of angle of rotation in tangent direction

$$\varphi_s^{(i)} = \frac{1}{2d} (w_{i+1} - w_{i-1}) \quad (10)$$

$$\varphi_s^{(i-1)} = \frac{1}{d} \left( -\frac{3}{2} w_{i-1} + 2w_i - \frac{1}{2} w_{i+1} \right) \quad (11)$$

$$\varphi_s^{(i+1)} = \frac{1}{d} \left( \frac{1}{2} w_{i-1} - 2w_i + \frac{3}{2} w_{i+1} \right) \quad (12)$$

The expressions (11) and (12) are needed for the nodes located on the left and right end of the free boundary.

### 3. Modelling of continuous internal support

In the expressions (1) and (5) there are continuous distribution of the internal support reaction. In proposed approach, the continuous reaction of single internal continuous support can be substituted by set of the elements of "constant" type (Fig. 7). The fundamental solution for thin plate  $w^*(\mathbf{y}, \mathbf{x}) = (1/8\pi D) r^2 \ln r$  has a singularity of the second order. Hence, the collocation point of internal single element

can be located at the centre of them and suitable diagonal integrals can be calculated analytically. The rest of integrals are calculated using 12-point Gauss quadrature.

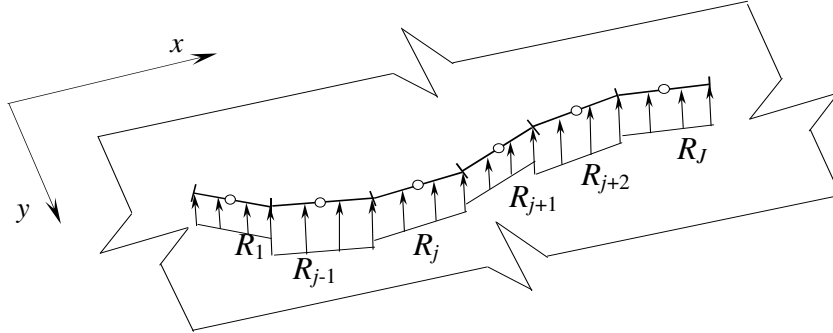

Fig. 7. Internal continuous supports: single element of the "constant" type

Using another approach, the internal continuous support can be treated as a column rectangular support with one edge dimension much smaller than the second, perpendicular (Fig. 8).

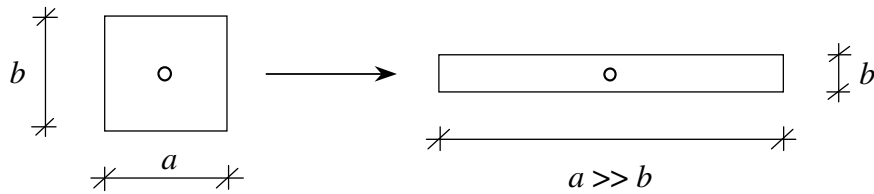

Fig. 8. Internal continuous supports: single element of the "constant" type

This element may be treated as internal sub-surface with one collocation point. In the paper, there will be applied the first approach (Fig. 7).

#### 4. Construction of set of algebraic equation

The case of the plate compressing by  $N_x$  forces is treated. Then, in the equation (1) and (5) takes a stand only the part  $N_x (\partial^2 w / \partial x^2)$ . The unknown variable in internal collocation points is the parameter  $\kappa = \partial^2 w / \partial x^2$ , the plate curvature in  $x$  direction [8, 11].

The elements of characteristic matrix:  $\mathbf{G}_{XX}$ ,  $\mathbf{G}_{rX}$ ,  $\mathbf{G}_{\kappa X}$ ,  $\mathbf{E}_{Xr}$ ,  $\mathbf{E}_{rr}$ ,  $\mathbf{E}_{\kappa r}$ ,  $\mathbf{E}_{X\kappa}$ ,  $\mathbf{E}_{r\kappa}$ , and  $\mathbf{E}_{\kappa\kappa}$  are the matrices containing integrals of suitable fundamental functions (Fig. 9). Matrices  $\mathbf{G}_{XX}$ ,  $\mathbf{G}_{rX}$  and  $\mathbf{G}_{\kappa X}$  depend from type of plate boundary. These integrals are calculated in local coordinate system  $n_i, s_i$  and then trans-

formed to coordinate system  $n_k, s_k$ . The quasi-diagonal elements of characteristic matrix were calculated analytically and rest of them numerically using Gauss quadrature.

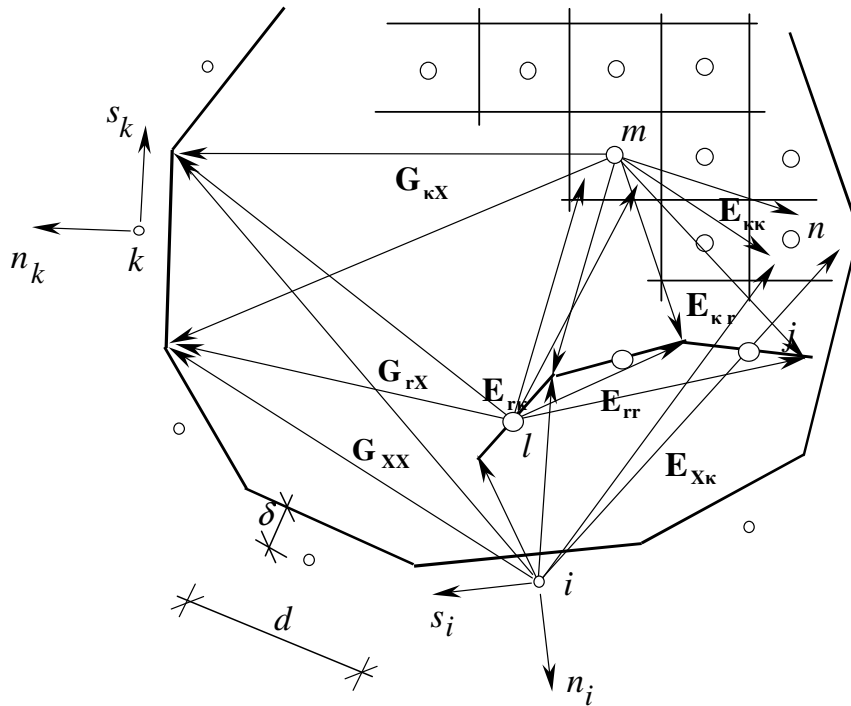

Fig. 9. Construction of set of algebraic equation

It is assumed, that normal loading is acting only along  $x$  direction,  $N_x \neq 0 = \text{const.}$ . In each internal collocation point, the unknown variable is the plate curvature  $\kappa_x$  (Fig. 10).

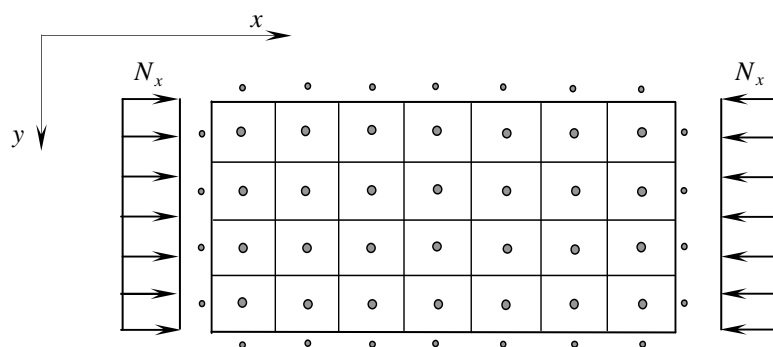

Fig. 10. Normal loading distribution



Hence, the set of algebraic equation can be written in the form:

$$\begin{bmatrix} \mathbf{G}_{XX} & \mathbf{E}_{Xr} & -\lambda \mathbf{E}_{X\kappa} \\ \mathbf{G}_{rX} & \mathbf{E}_{rr} & -\lambda \mathbf{E}_{r\kappa} \\ \mathbf{G}_{\kappa X} & \mathbf{E}_{\kappa r} & -\lambda \mathbf{E}_{\kappa\kappa} + \mathbf{I} \end{bmatrix} \begin{Bmatrix} \mathbf{X} \\ \mathbf{R}_r \\ \boldsymbol{\kappa} \end{Bmatrix} = \begin{Bmatrix} \mathbf{0} \\ \mathbf{0} \\ \mathbf{0} \end{Bmatrix} \quad (13)$$

where  $\lambda = N_{cr}$ ,  $\boldsymbol{\kappa} = \partial^2 \mathbf{w} / \partial x^2$  and  $\mathbf{I}$  is the unit matrix.

The third matrix equation in the set of equation (13) is obtained by construction of the boundary integral equations for internal collocation points. In this equation the fundamental solution derived by double differentiation of fundamental solution of Kirchhoff plate given by the formula (3) is applied. Elimination of boundary variables  $\mathbf{X}$  and the internal supports reaction  $\mathbf{R}_r$  vectors from matrix equation (13) leads to a standard eigenvalue problem:

$$\{\mathbf{A} - \tilde{\lambda} \cdot \mathbf{I}\} \boldsymbol{\kappa} = \mathbf{0} \quad (14)$$

where  $\tilde{\lambda} = 1/\lambda$  and

$$\mathbf{A} = \left\{ \left[ \mathbf{E}_{\kappa\kappa} - \mathbf{E}_{\kappa r} [\mathbf{E}_{rr}]^{-1} \mathbf{E}_{r\kappa} - \left( \mathbf{G}_{\kappa X} - \mathbf{E}_{\kappa r} [\mathbf{E}_{rr}]^{-1} \mathbf{G}_{rX} \right) \mathbf{B} \right] \right\} \quad (15)$$

$$\mathbf{B} = \left[ \mathbf{G}_{XX} - \mathbf{E}_{Xr} [\mathbf{E}_{rr}]^{-1} \mathbf{G}_{rX} \right]^{-1} \left( \mathbf{E}_{X\kappa} - \mathbf{E}_{Xr} [\mathbf{E}_{rr}]^{-1} \mathbf{E}_{r\kappa} \right) \quad (16)$$

## 5. Modes of buckling

The elements of the eigenvector  $\boldsymbol{\kappa}$  obtained after solution of the standard eigenvalue problem (14) present the plate curvatures. The set of the algebraic equation indispensable to calculate the eigenvector  $\mathbf{w}$  elements has a form:

$$\begin{bmatrix} \mathbf{G}_{XX} & \mathbf{E}_{Xr} & \mathbf{0} \\ \mathbf{G}_{rX} & \mathbf{E}_{rr} & \mathbf{0} \\ \mathbf{G}_{wX} & \mathbf{E}_{wr} & \mathbf{I} \end{bmatrix} \begin{Bmatrix} \mathbf{X} \\ \mathbf{R}_r \\ \mathbf{w} \end{Bmatrix} = \begin{Bmatrix} \lambda \mathbf{E}_{Xw} \boldsymbol{\kappa} \\ \lambda \mathbf{E}_{rw} \boldsymbol{\kappa} \\ \lambda \mathbf{E}_{ww} \boldsymbol{\kappa} \end{Bmatrix} \quad (17)$$

In the set of the equation (17) the first and the second equations are obtained from the first equation of (14). The third equation is gotten by construction of the boundary integral equations for calculating the plate deflection in internal collocation points. Elimination of the boundary variables  $\mathbf{X}$  and the internal continuous linear supports reaction  $\mathbf{R}_r$  from matrix equation (17) gives the elements of the wanted displacement vector  $\mathbf{w}$ :

$$\mathbf{w} = \lambda \left\{ \left[ \mathbf{E}_{ww} - \mathbf{E}_{wr} [\mathbf{E}_{rr}]^{-1} \mathbf{E}_{rw} - \left( \mathbf{G}_{wX} - \mathbf{E}_{wr} [\mathbf{E}_{rr}]^{-1} \mathbf{G}_{rX} \right) \mathbf{B} \right] \right\} \boldsymbol{\kappa} \quad (18)$$

## 6. Numerical examples

A rectangular plates rested on the internal continuous supports are considered. All results, are compared with analyses, prepared in the commercial finite element (FEM) code ABAQUS. In the FEM procedure the S4R (four nodes, reduced integration) element was used.

The set of boundary elements is regular. Each plate edge is divided by elements of the same length. The set of internal sub-surfaces is regular.

To simplify designations accepted:  $x_1 = x$  and  $x_2 = y$ . The collocation points of boundary elements are located slightly outside the plate edge:  $\varepsilon = \bar{\delta}/d = 0.001$ .

The critical force  $N_{cr}$  is expressed using non-dimensional term:

$$\tilde{N}_{cr} = \frac{N_{cr}}{D} \cdot l_x \cdot l_y \quad (19)$$

### 6.1. A rectangular plate, simply-supported on two opposite edges with two edges free and one internal continuous support under constant normal loading

Static and loading scheme is shown on Figure 11. The plate boundary was discretized using 160 number of boundary elements. Number of internal linear continuous elements is equal to 40 and number of internal sub-surfaces used to describe the plate curvature is equal: 200 (I) and 800 (II).

Regular finite element mesh  $0.5 \times 0.5$  m and element type of S4R with reduced integration (III) were assumed into analysis.

The following material properties were assumed into the analysis:  $E_p = 30$  GPa,  $\nu_p = 0.167$ .

The plate geometry is defined as:  $l_x = l_y = l = 10$  m,  $h_p = 0.2$  m (Fig. 11).

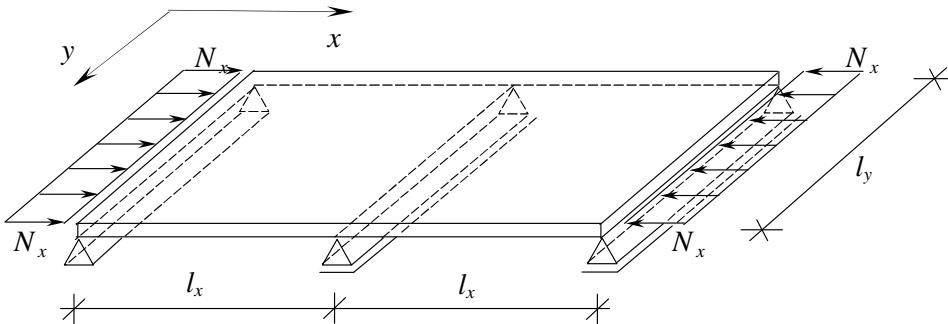

Fig. 11. A rectangular plate, simply-supported on two opposite edges with two edges free and one internal continuous support under constant normal loading

The first buckling mode is shown on Figure 12.

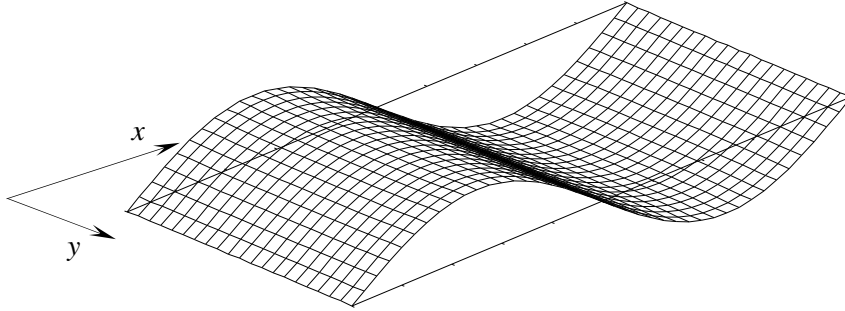

Fig. 12. The first buckling mode

The critical force values for BEM approach with different discretization and FEM approach are collocated in Table 1.

Table 1. Critical force values ( $\varepsilon = 0.001$ )

$\tilde{N}_{cr}$	BEM solution I	BEM solution II	FEM solution III
1	9.698770	9.702689	9.71620
2	20.111336	20.092051	20.37835
3	29.326732	29.324609	29.15035
4	39.541160	39.534728	38.68120

The influence of localization of collocation point on critical force values using BEM approach is presented in Table 2.

Table 2. Critical force values different value of  $\varepsilon$ . BEM solution I

$\varepsilon = \frac{\bar{\delta}}{d}$	$\tilde{N}_{cr}$			
	1	2	3	4
0.0001	9.699216	20.111669	29.329917	39.545984
0.001	9.698770	20.111336	29.326732	39.541160
0.01	9.694341	20.108175	29.296685	39.494578
0.1	9.663391	20.089560	29.071718	39.146946

## 6.2. A rectangular plate, clamped on two opposite edges with two edges free and one internal continuous support under constant normal loading

Static and loading scheme is shown on Figure 13. The plate boundary was discretized using 160 number of boundary elements. Number of internal linear conti-

nuous elements is equal to 40 and number of internal sub-surfaces used to describe the plate curvature is equal: 200 (I) and 800 (II).

The following material properties were assumed into the analysis:  $E_p = 30$  GPa,  $\nu_p = 0.167$ .

The plate geometry is defined as:  $l_x = l_y = l = 10$  m,  $h_p = 0.2$  m (Fig. 13).

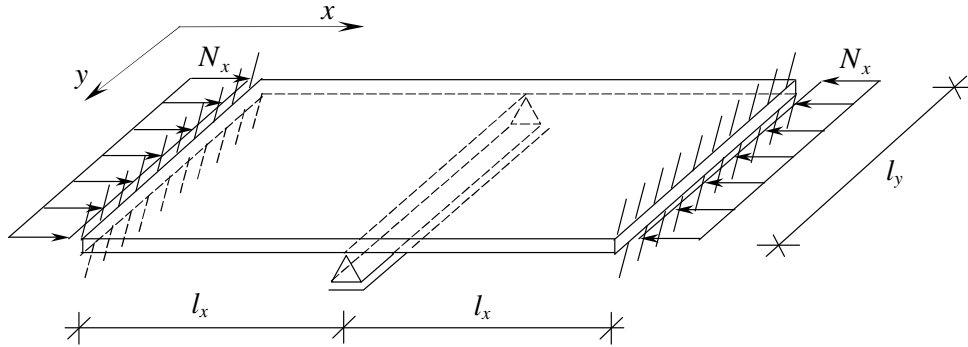

Fig. 13. A rectangular plate, clamped on two opposite edges with two edges free and one internal continuous support under constant normal loading

The first buckling mode is shown on Figure 14.

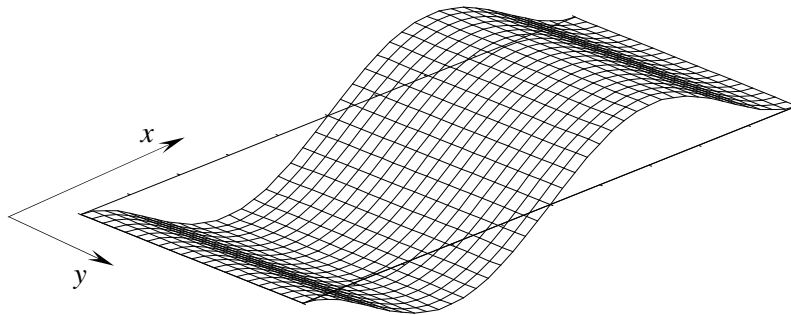

Fig. 14. The first buckling mode

The critical force values for BEM approach with different discretization are collocated in Table 3.

Table 3. Critical force values ( $\varepsilon = 0.001$ )

$\tilde{N}_{cr}$	<b>BEM solution I</b>	<b>BEM solution II</b>
1	20.067583	20.073964
2	39.659230	39.653730
3	39.788751	39.815148
4	59.381705	59.427004

The influence of localization of collocation point on critical force values using BEM approach is presented in Table 4.

Table 4. Critical force values for different value of  $\varepsilon$ . **BEM** solution I

$\varepsilon = \frac{\bar{\delta}}{d}$	$\tilde{N}_{cr}$			
	1	2	3	4
0.0001	20.067832	39.659877	39.790054	59.383664
0.001	20.067583	39.659230	39.788751	59.381705
0.01	20.064684	39.653406	39.778983	59.362489
0.1	20.050532	39.621086	39.728917	59.257128

### 6.3. A rectangular plate, simply-supported on all edges with one continuous support under constant normal loading

Static and loading scheme is shown on Figure 15. The plate boundary was discretized using 160 number of boundary elements. Number of internal linear continuous elements is equal to 40 and number of internal sub-surfaces used to describe the plate curvature is equal: 200 (I) and 800 (II).

The following material properties were assumed into the analysis:  $E_p = 30$  GPa,  $\nu_p = 0.167$ .

The plate geometry is defined as:  $l_x = l_y = l = 10$  m,  $h_p = 0.2$  m (Fig. 15).

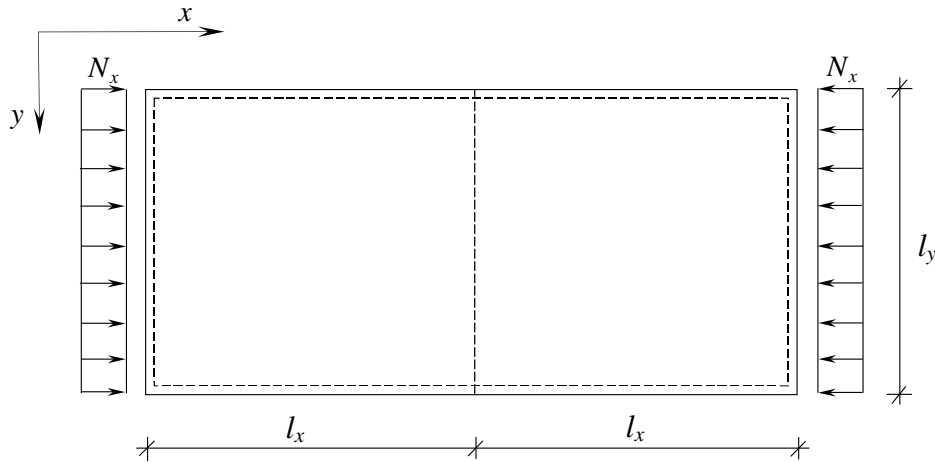

Fig. 15. A rectangular plate, simply-supported on all edges with one internal continuous support under constant normal loading

The first buckling mode is shown on Figure 14.

The critical force values for BEM approach with different discretization are collocated in Table 5.

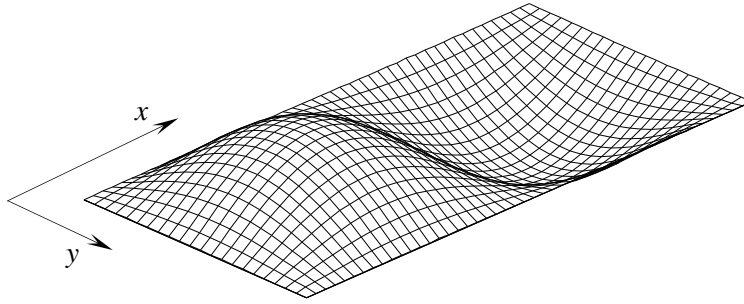

Fig. 16. The first buckling mode

Table 5. Critical force values ( $\varepsilon = 0.001$ )

$\tilde{N}_{cr}$	<b>BEM</b> solution I	<b>BEM</b> solution II
1	39.886040	39.876551
2	48.446876	48.434326
3	62.969636	62.955610
4	84.661945	84.645729

The influence of localization of collocation point on critical force values using BEM approach is presented in Table 6.

Table 6. Critical force values for different value of  $\varepsilon$ . **BEM** solution I

$\varepsilon = \frac{\bar{\delta}}{d}$	$\tilde{N}_{cr}$			
	1	2	3	4
0.0001	39.886040	48.446876	62.969555	84.661945
0.001	39.886040	48.446876	62.969636	84.661945
0.01	39.886367	48.447842	62.970126	84.662388
0.1	39.887022	48.449773	62.969636	84.661061

## Conclusions

An initial stability of thin plates considering internal linear supports was presented. The boundary integral equations in modified form were derived and the Boundary Element Method were used to solve the problem. The collocation version of boundary element method with constant elements and non-singular calculations of integrals are employed.

In this formulation, there is no need to introduce the Kirchhoff forces at a plate corners and the equivalent shear forces at a plate boundary. A normal loading distribution is constant along the plate edge. The high number of boundary elements and internal sub-surfaces is not required to obtain sufficient accuracy.

The loaded plate edge must be supported. This condition is required in proposed formulation of buckling analysis. In case of normal loading along the plate free edge, the boundary integral equation must be expanded by additional part:

$$\int_{\Gamma} -N_x \cdot \frac{\partial w_{\Gamma}}{\partial x} \cdot w^*(\mathbf{y}, \mathbf{x}) \cdot d\Gamma(\mathbf{y})$$

Then, construction of set of algebraic equation in matrix notation and formulation of the standard eigenvalue problem are much more complicated. To solve this problem, the first and second derivatives of deflection inside the plate area ( $\partial^2 w / \partial x^2$ ) and at the boundary ( $\partial w_{\Gamma} / \partial x$ ) can be calculated approximately by constructing a differential expression using deflections of suitable neighbouring internal collocation points and included collocation points located at the plate free edge. Proposed approach can be also applied to static analysis of plate considering loading acting in plane along normal or tangent direction.

## References

- [1] Bèzine G., A boundary integral equation method for plate flexure with condition inside the domain, *Int. J. Num. Meth. Engng.* 1981, 15, 1647-1657.
- [2] De Paiva J.B., Venturini W.S., Boundary element algorithm for building floor slab analysis, *International Conference of BETECH 85*, Adelaide, Australia, C.A. Brebbia, B.J. Noye (eds), Computational Mechanics Publications 1985, 201-209.
- [3] de Paiva J.B., Venturini W.S., Analysis of building structures considering plate-beam-column interactions, *International Conference of BETECH 87*, Rio de Janeiro, Brazil, C.A. Brebbia, W.S. Venturini (eds), Computational Mechanics Publications 1987, 209-219.
- [4] Hartmann F., Zotemantel R., The direct boundary element method in plate bending, *Int. J. Num. Meth. Engng.* 1986, 23, 2049-2069.
- [5] Abdel-Akher A., Hartley G.A., Evaluation of boundary integrals for plate bending, *Int. J. Num. Meth. Engng.* 1989, 28, 75-93.
- [6] Litewka B., Reissner plate analysis by the boundary element method considering interaction with liquid (in Polish), Poznan University of Technology, Poznan 2007.
- [7] Rashed Y.F., A coupled BEM-flexibility force method for bending analysis of internally supported plates. *Int. J. Num. Meth. Engng.* 2002, 54, 1431-1457.
- [8] Shi G., Flexural vibration and buckling analysis of orthotropic plates by the boundary element method, *Int. J. Solids Structures* 1990, 26, 1351-1370.
- [9] Guminiak M., Sygulski R., The analysis of internally supported thin plates by the boundary element method, Part 1 - Static analysis, *Foundation of Civil and Environmental Engineering* 2007, 9, 17-41.

- [10] Guminiak M., Sygulski R., The analysis of internally supported thin plates by the boundary element method, Part 2 - Free vibration analysis. *Foundation of Civil and Environmental Engineering* 2007, 9, 43-74.
- [11] Guminiak M., Jankowiak T., The analysis of internally supported thin plates by the boundary element method, Part 3 - Initial stability analysis, *Foundation of Civil and Environmental Engineering* 2007, 10, 51-67.
- [12] Hartley G.A., Development of plate bending elements for frame analysis, *Engineering Analysis with Boundary Element* 1997, 17, 2, 93-104.